

S3-SERIES REVERSE OSMOSIS SYSTEMS



S3-4125
Reverse Osmosis System

AXEON® S3-Series Reverse Osmosis Systems are engineered and manufactured for seawater applications specifically tailored for capacities ranging from 600 to 2,200 gallons per day. The **S3-Series Reverse Osmosis Systems** feature a unique and innovative compact design that allows for easy installation in any size area.

The S3-Series is also equipped with premium components, which include a 316L SS plunger-type pump for high performance, a high grade corrosion resistant aluminum frame, a programmable computer controller with many built-in features and fiberglass membrane housings for durability.

BENEFITS

- Fully Equipped and Customizable
- High Quality Components
- Individually Tested and Preserved
- Low Operation and Maintenance Costs
- Easy Maintenance and Servicing
- Pre-Plumbed, Wired and Assembled
- 1-Year Limited Warranty

AXEON Naming Matrix				
	S3	4	1	25
V-Series Model				
S3	Sea Water Model			
Housing Quantity Designation				
1	1 Vessels			
2	2 Vessels			
3	3 Vessels			
4	4 Vessels			
Membrane Quantity Per Housing				
1	1 Membranes			
2.5 Inch Membrane Diameter				

FEATURES

- S-150 Computer Controller
 - LCD Backlit Display
 - Pre-Treatment Lockout
 - Tank Level Input
 - Pressure Monitoring and Alarm
 - TDS Monitoring
 - Hour Meter
 - Feed Flush
- High Rejection Seawater Membranes
- AXEON FRP-Series Membrane Housings
- AXEON 5-Micron Sediment Pre-Filter
- Permeate and Concentrate Flow Meters
- 0-100 psi 316L-SS Glycerin-Filled Filter In Pressure Gauge
- 0-100 psi 316L-SS Glycerin-Filled Pre-Filter Out Pressure Gauge
- 0-1500 psi 316L-SS Glycerin-Filled Concentrate Pressure Gauge
- Plast-O-Matic Feed Solenoid Valve
- AXEON 316L Stainless Steel Needle Valve
- 316L SS Feed Low Pressure Switch
- 316L SS High Pressure Pump Switch

- CAT® 316L High Pressure Pump
- TEFC Motor with Thermal Motor Protection
- Chemical Pump Outlet
- Powder Coated Aluminum Frame
- High Pressure 316L Stainless Steel Tubing and Fittings
- High Pressure Hose with Reusable SS Fittings

OPTIONS AND UPGRADES

- Booster Pump
- High Pressure Tank Switch
- Permeate Divert Valve
- Fresh Water Flush
- Ultraviolet Light
- Wooden Shipping Crate

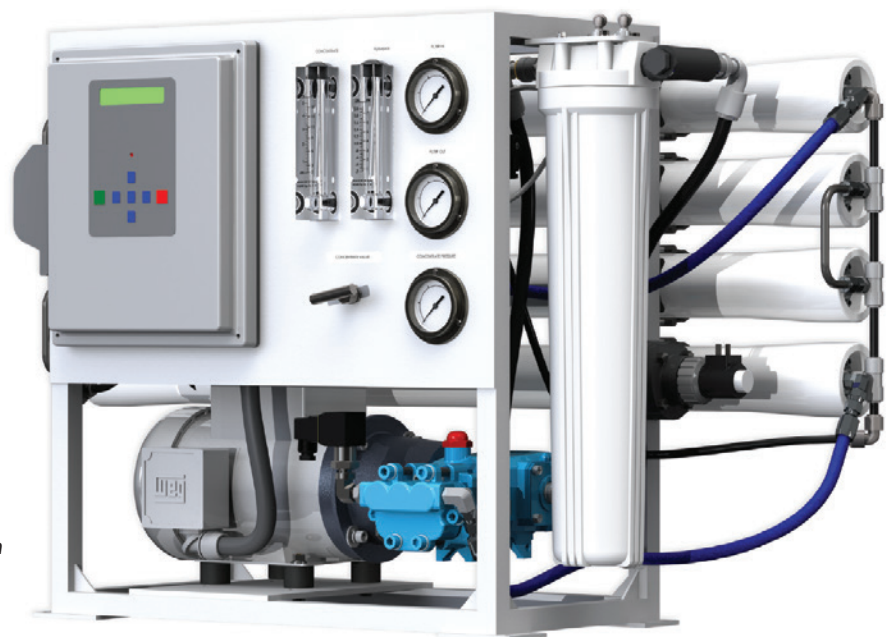

S3-4125
Reverse Osmosis System

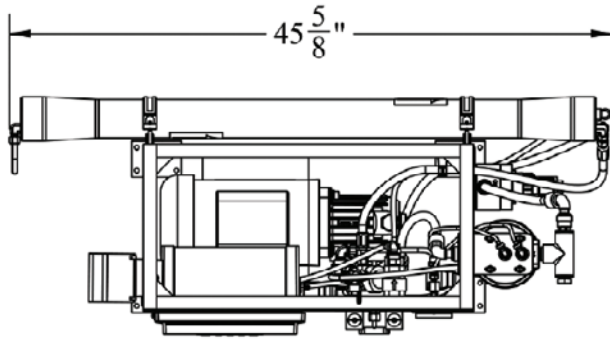

Notes:

All dimensions are given in inches.

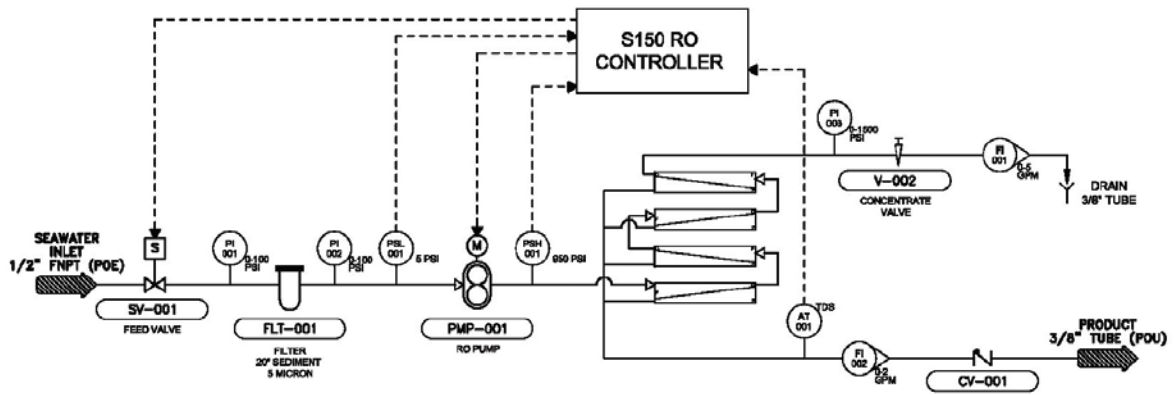
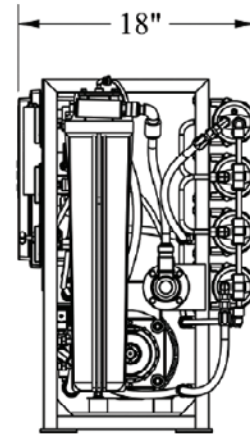
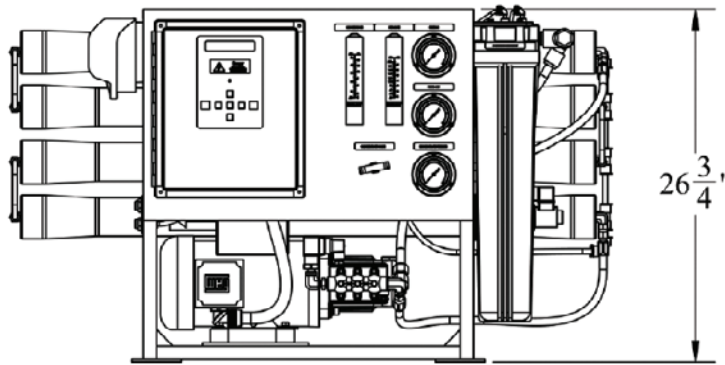

ARRAY SPECIFICATIONS

Model	Vessel Array	Vessel Size	Vessel Quantity	Membrane Size	Membrane Quantity
S3-1125	1	2540	1	2540	1
S3-2125	1:1	2540	2	2540	2
S3-3125	1:1:1	2540	3	2540	3
S3-4125	1:1:1:1	2540	4	2540	4

SPECIFICATIONS

MODELS	S3-1125	S3-2125	S3-3125	S3-4125
Design				
Configuration	Single Pass	Single Pass	Single Pass	Single Pass
Feedwater Source ^A	TDS < 35,000 ppm	TDS < 35,000 ppm	TDS < 35,000 ppm	TDS < 35,000 ppm
Standard Recovery Rate %	10	20	25	36
Rejection and Flow Rates^B				
Nominal Salt Rejection %	99	99	99	99
Permeate Flow (gpm / lpm)	0.41 / 1.55	0.83 / 3.14	1.25 / 4.73	1.52 / 5.75
Minimum Feed Flow (gpm / lpm)	4.20 / 15.90	4.20 / 15.90	4.20 / 15.90	4.20 / 15.90
Connections				
Feed FNPT (in)	1/2	1/2	1/2	1/2
Permeate Tubing (in)	3/8	3/8	3/8	3/8
Concentrate Tubing (in)	3/8	3/8	3/8	3/8
Membranes				
Membrane Per Vessel	1	1	1	1
Membrane Quantity	1	2	3	4
Membrane Size	2540	2540	2540	2540
Vessels				
Vessel Array	1	1:1	1:1:1	1:1:1:1
Vessel Quantity	1	2	3	4
Pumps				
Pump Type	Plunger	Plunger	Plunger	Plunger
Motor HP / KW	2.50 / 1.85	2.50 / 1.85	2.50 / 1.85	2.50 / 1.85
RPM @ 60Hz (50 Hz)	1725 / 1450	1725 / 1450	1725 / 1450	1725 / 1450
System Electrical				
Standard Voltage + Amp Draw	220VAC, 1PH, 11.9A ^C	220VAC, 1PH, 11.9A ^C	220VAC, 1PH, 11.9A ^C	220VAC, 1PH, 11.9A ^C
System Dimensions				
Approximate Dimensions ^D L x W x H (in / cm)	45.625 x 18 x 26.75 / 115.9 x 45.7 x 67.9	45.625 x 18 x 26.75 / 115.9 x 45.7 x 67.9	45.625 x 18 x 26.75 / 115.9 x 45.7 x 67.9	45.625 x 18 x 26.75 / 115.9 x 45.7 x 67.9
Approximate Weight (lbs / kg)	145 / 65.77	155 / 70.31	165 / 74.84	175 / 79.38

Test Parameters: 35,000 TDS Filtered (5-Micron), Dechlorinated, Municipal Feedwater, 45 psi / 3.1 bar Feed Pressure, 850 psi / 58.61 bar Operating Pressure, 77°F / 25°C, Recovery as stated, 7.0 pH. Data taken after 60 minutes of operation.

- A. Low temperatures and feedwater quality, such as high TDS levels will significantly affect the systems production capabilities and performance. Computer projections must be run for individual applications which do not meet or exceed minimum and maximum operating limits for such conditions.
 B. Product flow and maximum recovery rates are based on feedwater conditions as stated above. Do not exceed recommended permeate flow.
 C. Varies with motor manufacturer.
 D. Does not include operating space requirements.

OPERATING LIMITS^E

Maximum Feed Temperature (°F / °C)	85 / 29	Maximum Turbidity (NTU)	< 1
Minimum Feed Temperature (°F / °C)	41 / 5	Maximum Free Chlorine (ppm)	0
Maximum Ambient Temperature (°F / °C)	120 / 49	Maximum Hardness (gpg)	0
Minimum Ambient Temperature (°F / °C)	40 / 4	Maximum pH (continuous)	11
Maximum Feed Pressure (psi / bar)	60 / 4	Minimum pH (continuous)	2
Minimum Feed Pressure (psi / bar)	15 / 1	Maximum pH (cleaning 30 minutes)	13
Maximum Operating Pressure (psi / bar)	1000 / 69	Minimum pH (cleaning 30 minutes)	1
Maximum Feed Silt Density Index (SDI)	< 3		

E. System pressure is variable due to water conditions. Permeate flow will increase at a higher temperature and will decrease at a lower temperature.

800-320-4074

AXEONwater.com

