

Membrane System User Manual

RF – Series
4–Stage, 5–Stage,
5–Stage with Booster Pump



5–STAGE RESIDENTIAL
REVERSE OSMOSIS SYSTEM PICTURED

This page intentionally
left blank

TABLE OF CONTENTS

TOOLS AND MATERIALS FOR INSTALLATION.....	4
ESTIMATED REPLACEMENT AND FILTER CHANGE	4
PRE-INSTALLATION INSPECTION.....	4
OPERATION PARAMETERS	5
MEMBRANE AND FLOW RESTRICTOR ASSEMBLY PROCESS	6
PREPARING FOR INSTALLATION	9
FAUCET INSTALLATION	9
INSTALLATION AND FEEDWATER ADAPTER	11
INSTALLATION OF DRAIN SADDLE.....	13
POSITIONING THE TANK.....	13
REVERSE OSMOSIS UNIT PLACEMENT AND MOUNTING.....	13
TUBING CONNECTIONS	14
SYSTEM START-UP.....	14
FLUSHING THE REVERSE OSMOSIS SYSTEM.....	15
TROUBLESHOOTING	16
SYSTEM DRAWINGS.....	18
SYSTEM WARRANTY	21

PLEASE READ CAREFULLY BEFORE PROCEEDING WITH INSTALLATION

TOOLS AND MATERIALS FOR INSTALLATION:

- Variable speed (VS) drill
- Carbide grinding burr
- 1/4" (6mm) drill bit
- 7/16" (11mm) drill bit
- 1/2" (13mm) and 5/8" (16mm) open-end wrenches (or adjustable)
- Phillips screwdriver
- Flashlight or droplight
- Teflon tape
- Protective eyewear (i.e. goggles)

If the above tools are not available, contact your local dealer/distributor for assistance.

ESTIMATED REPLACEMENT AND FILTER CHANGE:

Sediment Prefilters:	6 months – 1 year
Carbon Prefilters:	6 months – 1 year
Carbon Postfilter:	6 months – 1 year
Reverse Osmosis Membrane:	1 – 2 years

NOTE: The life of the filters and membrane depend on the quality of water supplied to the reverse osmosis system.

PRE-INSTALLATION INSPECTION:

After opening the shipping container, locate the following items:

1. Reverse osmosis system
2. Storage tank
3. Faucet with mounting hardware
4. Installation packet containing: drain saddle, tank ball valve, two mounting screws and other installation pieces depending on system.

OPERATION PARAMETERS:

WARNING!! The following conditions for feedwater supply must be met or warranty will be void.

1. System must be connected to a municipal or well water source that is treated and tested on a regular basis to insure water is microbiologically safe.
2. Operating outside temperatures:

Maximum 90 °F

Minimum 40 °F

CAUTION!! Do not allow system to freeze. The membrane always contains water and will be destroyed if frozen.

WARNING!! Do not plumb system to hot water. This will destroy the membrane and void the warranty and manufacturer's responsibility.

3. Operating pressure:

Maximum 80 PSI

Minimum 40 PSI

This reverse osmosis system is designed to operate at a water pressure in the range of 40 to 80 PSI. At pressures lower than this, the quantity as well as quality will be reduced. At higher pressure, severe damage to the system may result. **A pressure regulator must be installed on the feedwater source, which reduces the water pressure coming into the system.**

WARNING!! Warranty voided and manufacturer assumes no responsibility for damage to system or property if pressure exceeds 80 PSI.

4. Turbidity: <1 NTU
5. pH: 4 to 11
6. Recommended hardness not to exceed 7 grains per gallon or 120 PPM.

RECOMMENDATION – If your water hardness exceeds 7 grains per gallon or 120 PPM you may wish to purchase a water softener. Contact your local dealer or distributor for pricing and availability.

7. Recommended Total Dissolved Solids (TDS) not to exceed 1000 PPM.

WARNING!!! The installer is responsible and liable for any leaks resulting from installation of tubing or related fittings. The installer must check over the entire system completely while under pressure to ensure system is not leaking and functioning properly. Liability resulting from failure to check for leaks under pressure is the sole responsibility of the installer.

1

Preparing for Installation

Preparing for installation:

1. This system includes a standard sink top faucet without an air-gap. In localities where plumbing codes require installation of an air-gap, contact your local distributor to obtain a code approved drain line adapter.
2. The reverse osmosis system may be mounted to the side of the sink cabinet or set on the floor of the sink cabinet. It must be positioned to allow access for service and filter changes. The assembly should be relatively near the faucet to maximize flow rate. *See Diagram A* for a positioning example.
3. The storage tank should be located where it can be removed if necessary. The storage tank may be placed in either the vertical or horizontal position without affecting the system performance. If there is insufficient space under the sink for placement, the tank may be located in an adjacent cupboard up to 50 ft. away. *See Diagram A* for a positioning example.
4. The faucet should be positioned to allow a free flow pattern into the sink. It must be positioned to allow ready access to the mounting hardware under the sink. *See Diagram A* for a positioning example.



Diagram A

2

Faucet Installation

CAUTION!! Extreme care must be taken in drilling the hole for the sink-top faucet. The surface material of most sinks is extremely hard and brittle and can be easily chipped or cracked. If you are uncomfortable performing the following procedure, it is recommended that your local distributor be consulted for techniques and other assistance. The system's manufacturer accepts no responsibility for sink top damage resulting from system installation.

CAUTION!! Before grinding or drilling, put on appropriate eye protection (i.e., goggles) to protect yourself from porcelain or metal chips.

CAUTION!! Before grinding or drilling, ensure that the drill you are using is UL® Laboratories approved and properly grounded to prevent electrical shock. **DO NOT USE DRILL WHILE USING OR STANDING IN WATER!!**

1. **BEFORE DRILLING:** Check under the sink in the area that you plan to install the faucet and make sure that there is a flat surface to secure the mounting hardware. A flat space of approximately two inches in diameter is needed.

RECOMMENDATION: Before drilling or grinding mask off the immediate area, surround the grinding/drilling location, preferably with duct tape or if duct tape is unavailable masking tape may be used. This procedure should help prevent scratching of the sink surface.

2. Remove everything from inside the sink and surrounding area. Place paper towels in the sink to catch the shavings from the grinding and drilling.

CAUTION!! Porcelain or enamel must be completely removed in the drilling area to prevent immediate dulling of drill bit.

3. Remove everything from under the sink.

4. Place newspaper or paper towels directly under drilling location in order to catch the drill shavings.
5. Using the 1/4" (6mm) drill bit, drill a centering or pilot hole in the center of the desired faucet location. Note: this centering/pilot hole will make it easier for the 7/16" (11mm) drill bit to cut through the sink. Operate the drill slowly and carefully — especially when the drill bit is about to penetrate the metal. Otherwise, damage to sink may occur. Use lubricating oil to keep the drill bit cool while drilling.
6. Discard paper towels and newspaper used in sink and below sink. Be very careful not to drop any shavings in sink or on the floor as they will oxidize and stain surfaces very quickly.
7. Using a variable speed (VS) drill with a carbide grinding burr, gently grind away enough porcelain or enamel to accommodate the 7/16" (11mm) drill bit, approximately the size of a dime. Enough surface material must be removed to expose the base metal.

HELPFUL HINT: If you notice any rust spots from dropped shavings you should be able to get rid of them by scrubbing them with a cleaning chemical.

8. Cover the drilled hole with your finger. **BE VERY CAREFUL NOT TO CUT YOURSELF ON SHARP EDGES!** Rinse sink then scrub with cleaner to prevent any rusting from shavings and to prepare for faucet installation. Plug hole again while rinsing off cleaner. Hole must be plugged in order to avoid water dripping below into sink cabinet, which may cause damage.
9. Remove faucet from package.

For steps 11–14 refer to Diagram B.

10. Slip the small, thin rubber gasket over the faucet shank. Next, slip the chrome trim plate (escutcheon plate) over the faucet shank. Finally, slip the large, thin rubber gasket over the faucet shank.

11. Take the faucet spigot and insert it into the faucet base in the hole next to the faucet handle. Push the faucet spigot in until it stops.
12. Place the faucet shank through the drill hole completely, with only the hardware described in step 11.
13. From under the sink, slip the large, black plastic locating washer over the faucet shank. Next, slip the lock washer over the faucet shank followed by the thin brass nut.
14. While holding the faucet assembly above the sink, tighten the thin brass nut below the sink with an adjustable wrench. Tighten the brass nut until the faucet assembly does not move.

CAUTION!! Do not over tighten the brass nut. Over tightening can cause damage to the sink or faucet assembly.

Faucet Diagram

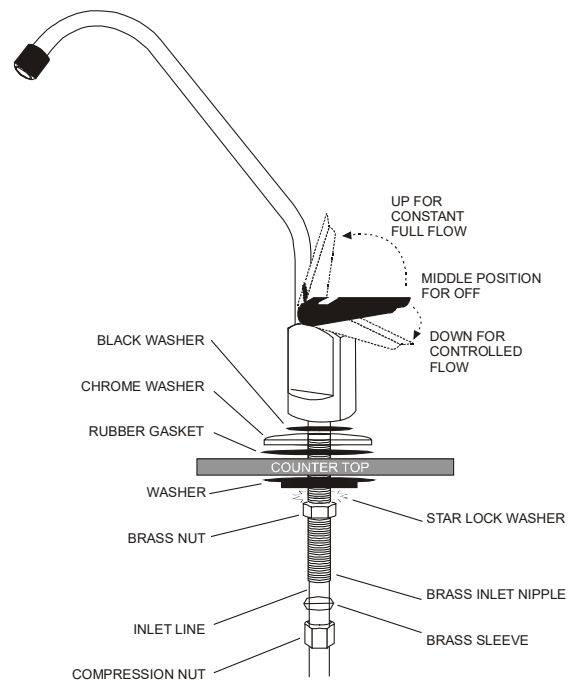

DIAGRAM B

3

Installation of Feedwater Adapter

CAUTION!! For your safety and protection, do not use where water is microbiologically unsafe or of unknown quality. The water supply to your system **MUST** be from the **COLD WATER LINE!** Hot water will severely damage your reverse osmosis system!

If you have a self-piercer assembly, skip to step # 8.

Note: In some cases, the supply valve may leak or may not work at all. If this happens, turn off the water at the main water shut off for the entire house. In extreme cases, the house shut off valve does not work. If this happens, shut the water off at the street and replace the defective valves immediately.

Locate the type of shut off valve you have under your sink and follow that step for connecting the feedwater.

1. Turn off cold water supply to the sink using the supply valve located under the sink.
2. Some shut off valves have an extra port for an icemaker hookup. You will not need the feed water adapter for this type of installation. See *Diagram C*.
3. On some shut off valves, you can install the feed water adapter directly to the valve. Slip the black washer into the feedwater adapter. Tighten feedwater adapter to the valve with an adjustable wrench. Tighten until snug. Insert the 1/4" brass straight fitting into the feed water adapter. **TIGHTEN BY HAND ONLY! DO NOT OVERTIGHTEN!** See *Diagram D*.
4. Most under sink shut off valves have a built in smooth or corrugated riser going up to the faucet. Refer to *Diagram E* for help with this type of valve. Secure an adjustable wrench to the fitting on the cold water side of the sink faucet – **NOT THE REVERSE OSMOSIS FAUCET!** Secure another adjustable wrench to the smooth /corrugated riser line nut. Gently undo the riser line from the sink faucet. Do not be alarmed! There will be water left in the line—this is normal. However, if the flow does not stop you probably haven't shut the water off properly.

(See the Note in Step # 1, Section # 3 if you need help with water shut off.)

5. Insert the black rubber washer into the feedwater adapter. Screw the adapter onto the fitting coming from the cold water side of the sink faucet. Using two adjustable wrenches, tighten the feedwater adapter to the cold water line. Take extreme care not to twist or damage the connection to the cold water connection.

CAUTION!! Tightening the connector improperly to the faucet could cause irreparable damage to the faucet.

6. Connect the riser from the water shut off valve to the feedwater adapter. Ensure that the cone washer on the riser tube is in good condition. With one adjustable wrench on the feedwater adapter and another adjustable wrench on the riser nut, connect the riser to the feed water adapter. **DO NOT OVER TIGHTEN!** This can cause damage to the riser connection.
7. Insert the 1/4" brass straight fitting into the feed water adapter. **TIGHTEN BY HAND ONLY! DO NOT OVERTIGHTEN!**

Self-Piercer Installation Instructions

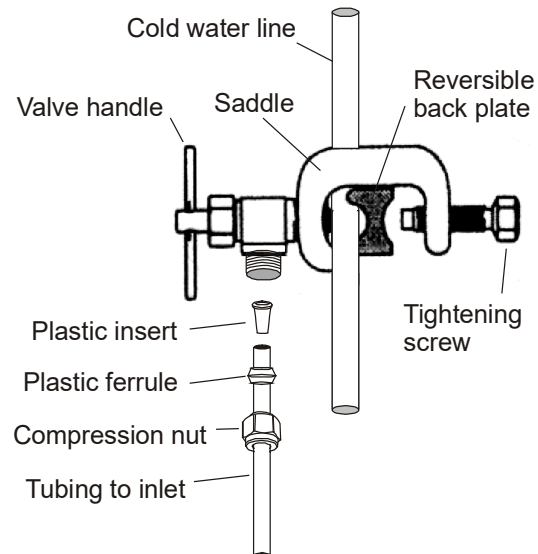

Self-piercer valve

NOTE: Self-piercer assembly can only be installed on smooth riser lines.

- Clamp the self-piercer onto the riser tube. Fit the adjustable aluminum bracket to the size of your riser tube. Then tighten locking nut until clamp is firmly attached to riser line.

CAUTION!! DO NOT OVER TIGHTEN!! This will crush the riser tube and destroy it.

- To pierce the line, simply screw the T-handle valve clockwise until it stops.

NOTE: If hole in copper tube (cold water line) is not adequately pierced, this may prevent sufficient cold water supply to the system and reduce the performance of reverse osmosis processing. In this event, open and close the self-piercing valve several times.

Feedwater Diagrams

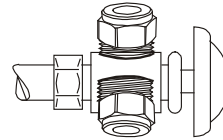

Insert tubing into adaptor for ice maker.

DIAGRAM C

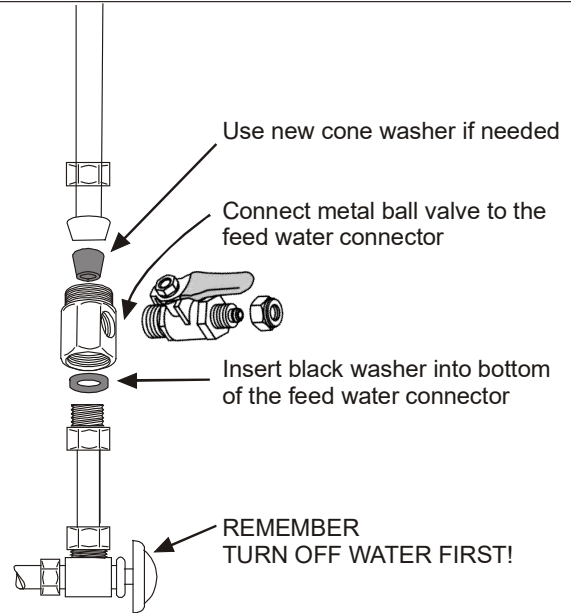

DIAGRAM D

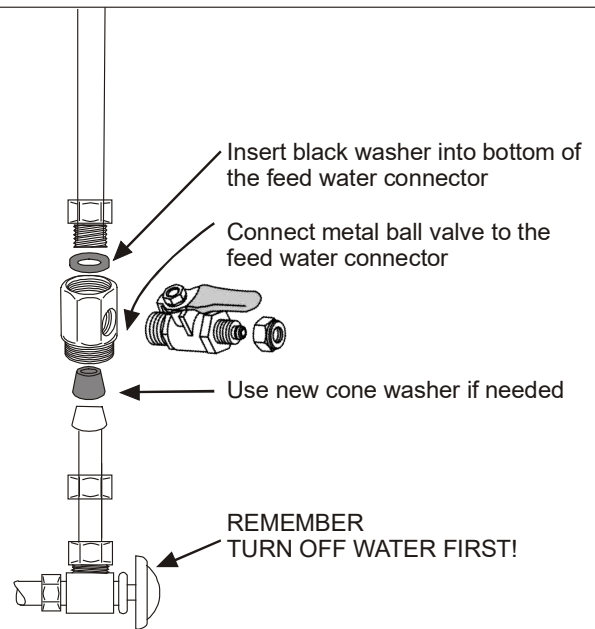

DIAGRAM E

3a

Installation of Angle Stop Valve

1. Turn off cold water supply to the sink using the supply valve located under the sink.
2. Remove the sink faucet "whip hose" or tubing from the shutoff valve. There will be residual water spilled when this tube is removed. Be sure to have a towel to dry the water that is spilled. Now install the angle stop valve on the sink faucet shutoff valve and tighten it. Use two wrenches to hold the valve while tightening. Don't worry about the angle stop valve position because it will swivel and can be positioned later.
3. Install the whip hose or tubing on the angle stop valve and tighten.
4. Be sure the blue handle on the angle stop valve is in the closed position. Now open the sink shutoff valve and check the angle stop connections for leaks. If there are leaks, repair them now. If there are no leaks, connect the red tubing to the angle stop valve. Leave the other end of this tubing unconnected for now. It will be connected later in the installation.



4

Installation of Drain Saddle

1. Open the package containing the drain saddle. See *Diagram F*.

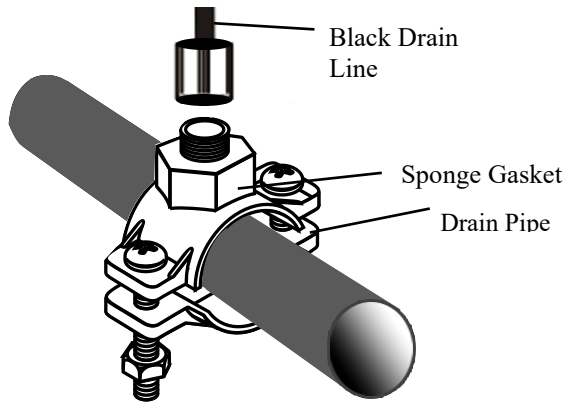

2. Peel the protective film off of the sponge gasket. Apply gasket to inside of drain saddle, using care to align sponge gasket hole with drain port.
3. Position the drain saddle on the vertical or horizontal drainpipe from your sink. Position as far away from the garbage disposal as possible.

DANGER!! The drain saddle **MUST** be installed on the side of the P-trap that goes to the sink drain! If installed on the wrong side of the P-trap, sewer gas could enter the unit and damage it.

4. Drill 1/4" (6mm) hole into the drainpipe.

CAUTION!! Be very careful when drilling into drainpipe to not drill all the way through—stop after piercing the first wall of the pipe.

5. Mount the drain saddle. Align the drain saddle port with the 1/4" drilled hole using a small drill bit or other small straight object.
6. **GENTLY TIGHTEN** the two screws evenly on both sides of the clamp until the clamp is snug on the pipe.

CAUTION!! To avoid breaking plastic saddle or crushing drainpipe **DO NOT OVER TIGHTEN!**

5

Positioning the Tank

1. Wrap four to five wraps of Teflon tape around the tank threads at the top of the tank.
2. Hand tighten the plastic shut off ball valve to tank stem.

CAUTION!! Hand tighten the valve only! **DO NOT OVERTIGHTEN!** If valve is overtightened it will crack and will leak.

IMPORTANT!! The tank pressure must be between 8 – 10 PSI when measured empty. This must be measured with a good dial or digital pressure gauge. A pop-up tire gauge will not give you an accurate reading. If you do not have access to a good gauge, contact your local distributor to purchase one.

If your tank pressure is above 10 PSI, use the tank valve to release pressure until there is between 8 – 10 PSI. If your tank pressure is below 8 PSI, use a bicycle pump to increase pressure between 8 – 10 PSI.

3. The storage tank should be located where it can be removed if necessary. The storage tank may be placed in either the vertical or horizontal position without affecting the system performance. If there is insufficient space under the sink for placement, the tank may be located in an adjacent cupboard up to 50 feet away.

6

Reverse Osmosis Unit Placement and Mounting

1. Determine if mounting of the reverse osmosis system is necessary or desired. The system does not need to be mounted on the wall of the cabinet if there is room for it to sit on the floor. However, if it is mounted to the side of the cabinet it is easier to change the filters and does not take up floor space.

IMPORTANT!! Be very careful not to kink any of the tubing on the reverse osmosis system. If tubing is kinked, the tubing can rupture and leak.

2. Position the system on the wall at the desired mounting location. Using the bracket holes on the back of the bracket, mark on the wall with a pencil where the screws need to be inserted.
3. Set the system aside.
4. Screw the two (2) Phillip head screws (supplied in the installation packet) into the wall at the marked positions.

NOTE: Let the screw heads protrude from the wall enough to hang the reverse osmosis system safely.

5. Mount the reverse osmosis system onto the screws.

7 Tubing Connections

IMPORTANT!! Be very careful not to kink any of the tubing on the reverse osmosis system. If tubing is kinked the tubing can rupture and leak.

CONNECTING THE FAUCET: (Blue Line)

1. Connect the blue tubing to the faucet by installing the QC faucet fitting.
2. Push the blue line all the way into the faucet fitting and ensure it can not be pulled out.

CONNECTING THE FEEDWATER: (Red Line)

1. If you installed the feedwater adapter using step # 3 or # 4 in Section # 3, simply slip a white 1/4" nylon nut over the red line and insert the 1/4" nylon insert into the end of the tubing. Then insert the tubing into the nylon

fitting on the feedwater adapter. Tighten the nylon nut securely.

DO NOT OVERTIGHTEN!

2. If you have the connection for the icemaker tee as in Step # 2 of Section # 3 simply slide the 1/4" brass nut over the red tubing. Slip the nylon ferrule over the red tubing and insert the 1/4" nylon insert into the tubing end. Insert tubing into the cold water shut off valve and tighten securely.
DO NOT OVERTIGHTEN!

CONNECTING THE TANK: (White Line)

1. Push in the white tubing and insert it into the 1/4" push pull fitting. Then insert the tubing into the ball valve on the top of the storage tank. Tighten securely.
DO NOT OVERTIGHTEN!

CONNECTING THE DRAIN SADDLE LINE: (Black Line)

1. Slip the 1/4" black nylon nut over the black tubing and insert into the drain saddle. Tighten securely. **DO NOT OVERTIGHTEN!**

Note: It is not necessary to have a 1/4" nylon insert in this line as there is no pressure on this line.

8 System Start-Up

1. With all connections complete, turn on the cold water supply to the reverse osmosis system.

IMPORTANT!! The Reverse Osmosis Main Water Shut Off Valve (indicated by the bright orange tag at the side of the unit) must be open. This means the blue handle on the valve must be in line with the red tubing; not pointing straight up.

2. Immediately check entire reverse osmosis system and tank for leaks. If you notice any leaks, turn off cold water supply and fix the leak.

IMPORTANT!! Ensure that the ball valve on the storage tank is open. This means that the valve handle is in line with the white tubing.

9

Flushing the Reverse Osmosis System

1. Lift the reverse osmosis faucet handle until it locks in the upright position. Let the water drip for two hours. After 2 hours, turn off the reverse osmosis faucet. The tank will now fill, which takes approximately four to five hours.
2. After the tank has filled, open the faucet and drain all the water from the tank until it is empty.

CAUTION!! DO NOT USE FIRST TANK OF WATER FROM YOUR SYSTEM! The membrane contains a food grade preservative to protect it while in storage. This preservative is not harmful; however, it does not have a pleasant taste. Therefore, do not use the first tank of water, which flushes the entire system removing any preservatives used during storage and preparing it to produce quality water.

3. Within two to three hours after draining the first tank of water, the water is ready for drinking.

12

TROUBLESHOOTING

Not Enough Water From Holding Tank

Possible Cause	Solution
Feedwater valve is plugged or closed.	Open valve or unclog.
Sediment/carbon prefilter or carbon post filter is clogged.	Replace filters.
Low incoming water pressure.	Incoming water pressure must be above 40 PSI. Install a booster pump or permeate pump.
Reverse osmosis membrane is fouled.	Make sure incoming water pressure is within operating limits. Make sure drain line is not clogged. (See High TDS) Correct cause of fouling and replace reverse osmosis membrane.
Air pressure in holding tank is incorrect.	Empty water from holding tank. Air pressure in valve stem should be between 8 – 10 PSI.
Air bladder in holding tank is ruptured.	Replace holding tank.
Holding tank valve is closed.	Open valve.
No water to drain. Drain flow restrictor is clogged.	Replace drain flow restrictor.
No water to drain. Air gap faucet is clogged.	Clear or replace air gap faucet.
Check valve on the reverse osmosis membrane housing is stuck.	Replace check valve.
The automatic shut-off valve is malfunctioning.	Replace automatic shut-off valve.

Low Water Pressure From Dispensing Faucet

Possible Cause	Solution
Air pressure in holding tank is incorrect. This is the #1 reason for low flow from reverse osmosis faucet.	Open faucet and empty water from holding tank. Shut off feedwater to system and remove holding tank from under sink. (The tank is easier to work on.) Locate the air valve stem (just like on a car or bicycle tire) and add air. If there is still water in the tank, continue to add air until all the water is removed. Once all the water is removed, continue to add air and pressurize to 8 PSI. Re-install the tank under the sink, turn on the feed supply to the system and allow the tank to fill.
Carbon post filter is clogged.	Replace post filter
Holding tank valve is partially closed.	Open valve.
The faucet is out of adjustment or faulty.	Repair or replace faucet.
Heavy water use. Holding tank is empty.	Allow holding tank to refill.
Low water production.	See section on <i>Low Quantity of Water from Holding Tank</i> .

Product Water is High in Total Dissolved Solids (TDS)

Possible Cause	Solution
Clogged prefilter.	Replace filter.
Low incoming water pressure.	Incoming water pressure must be above 40 PSI. Install a booster pump or permeate pump.
Reverse osmosis membrane is not correctly sealed in membrane housing.	Check that the reverse osmosis membrane is correctly installed.
Reverse osmosis membrane is expended.	If membrane life is unusually short, find and correct the problem. (Average life is two to three years.) Replace Reverse Osmosis membrane.
Product water and drain water lines are reversed.	Correct plumbing.
No water to drain. Drain flow restrictor is clogged.	Replace drain flow restrictor.
No water to drain. Air gap faucet is clogged.	Clear or replace air gap faucet.
The automatic shut-off valve is not closing.	Repair or replace automatic shut-off valve.
New carbon postfilter has not been rinsed completely.	Drain holding tank twice to rinse new carbon postfilter.
The incoming feedwater TDS has increased.	An increase in feedwater TDS will also give an increase in product water TDS.

Tastes and Odors in Product Water

Possible Cause	Solution
Carbon post filter is exhausted.	Replace filter.
There is foreign matter in holding tank.	Clean, flush and sanitize the holding tank. Replace filters.
Product water and drain water lines are reversed.	Correct plumbing.
Dissolved gases in feedwater.	Pre-treat feedwater to remove gasses.
Increase in product water TDS.	See <i>High TDS in Product Water</i> Section

Drain Water Overflows at the Air Gap Faucet

Possible Cause	Solution
Air gap is clogged.	Clear air gap
Drain line is clogged.	Clear tubing.
Drain flow rate is too high.	Replace flow restrictor.

Faucet Leaks or Drips

Possible Cause	Solution
Water leaks from faucet spout.	Adjust faucet by turning the tee bar located under the handle to provide a small amount of free play in the handle when shut off. Should this not work, repair or replace the faucet.
Leaks from beneath the handle.	Repair or replace the faucet.

SYSTEM DRAWINGS

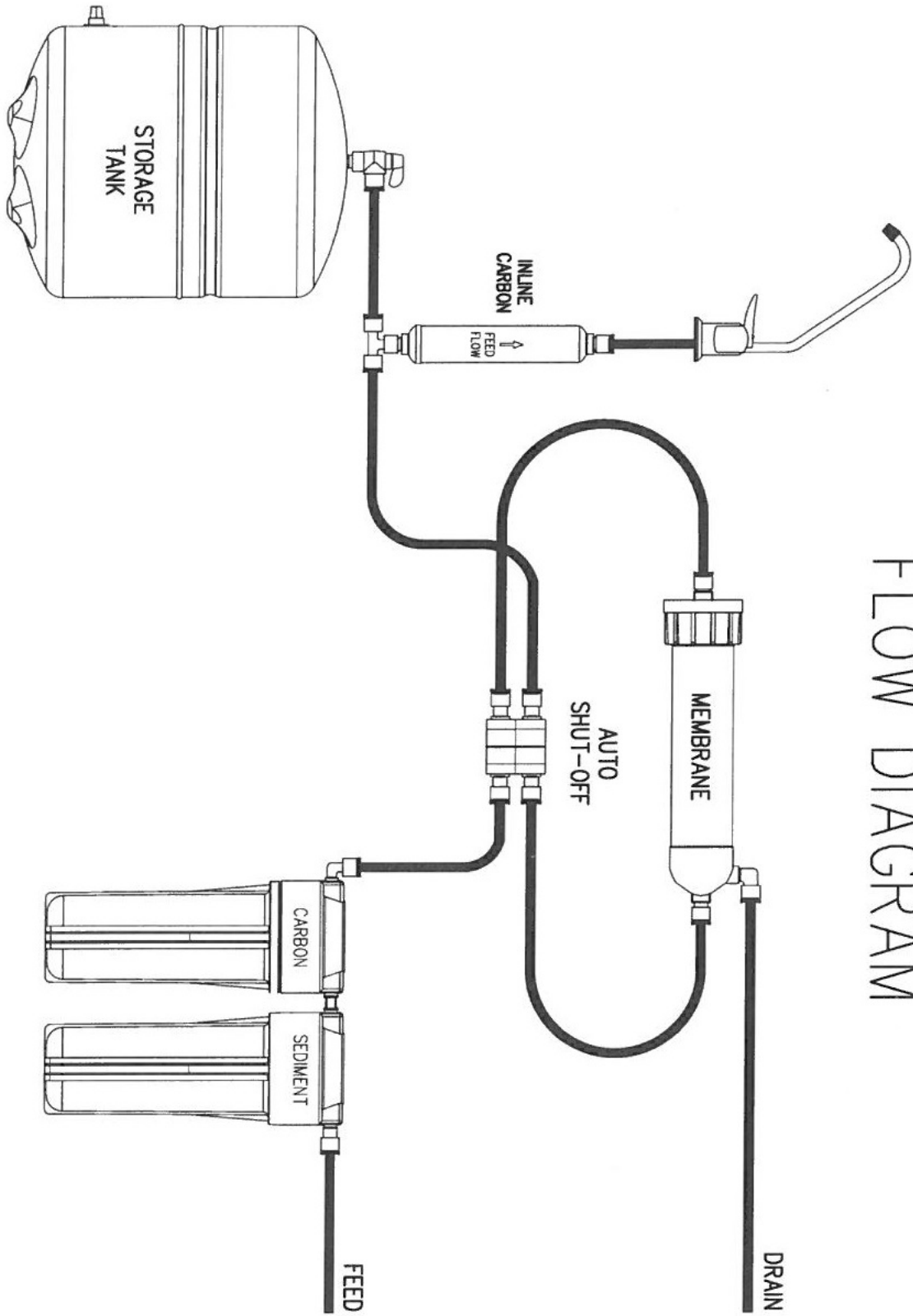

4 STAGE FLOW DIAGRAM

5 STAGE FLOW DIAGRAM

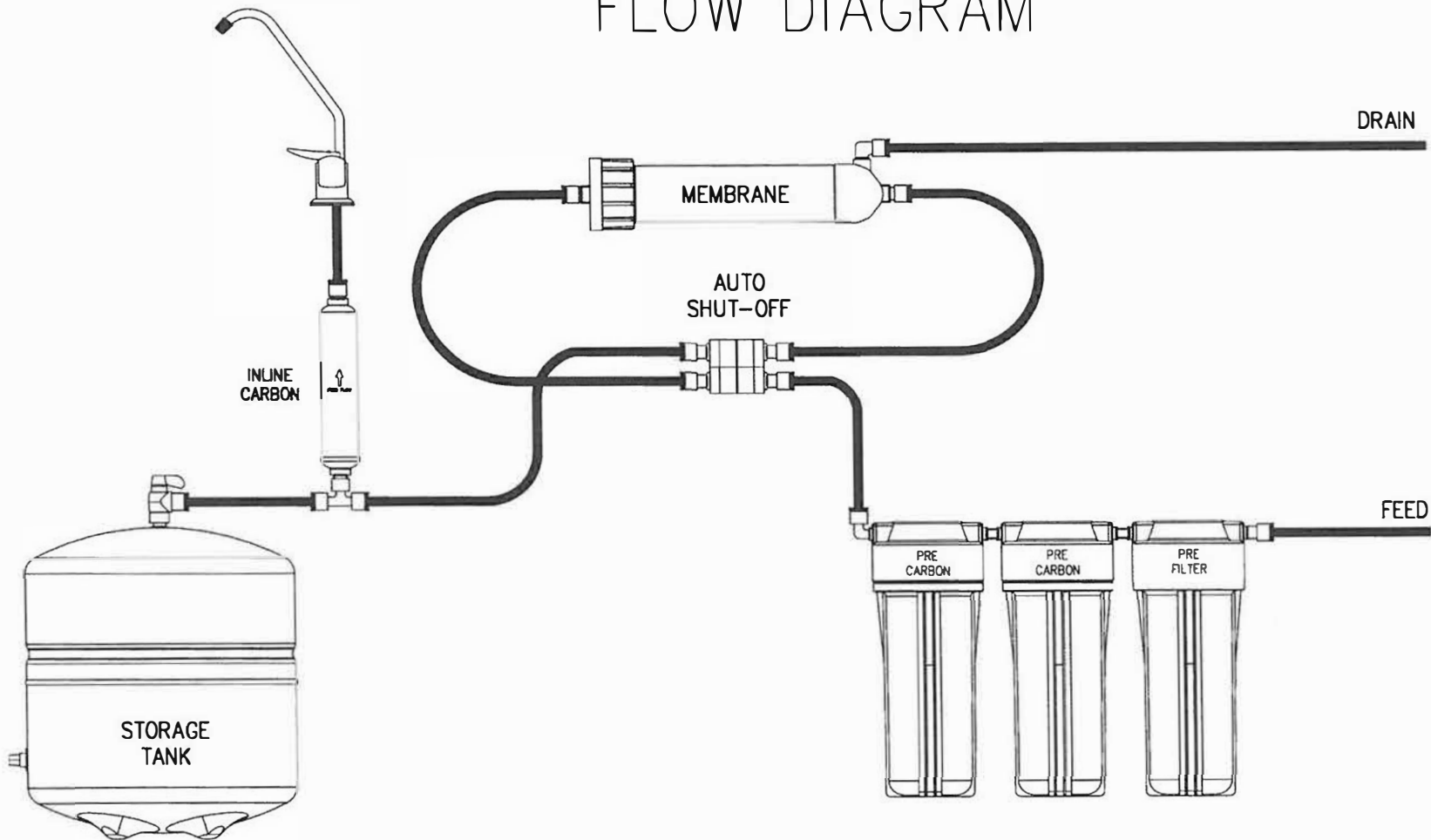

5 STAGE BOOSTER PUMP FLOW DIAGRAM

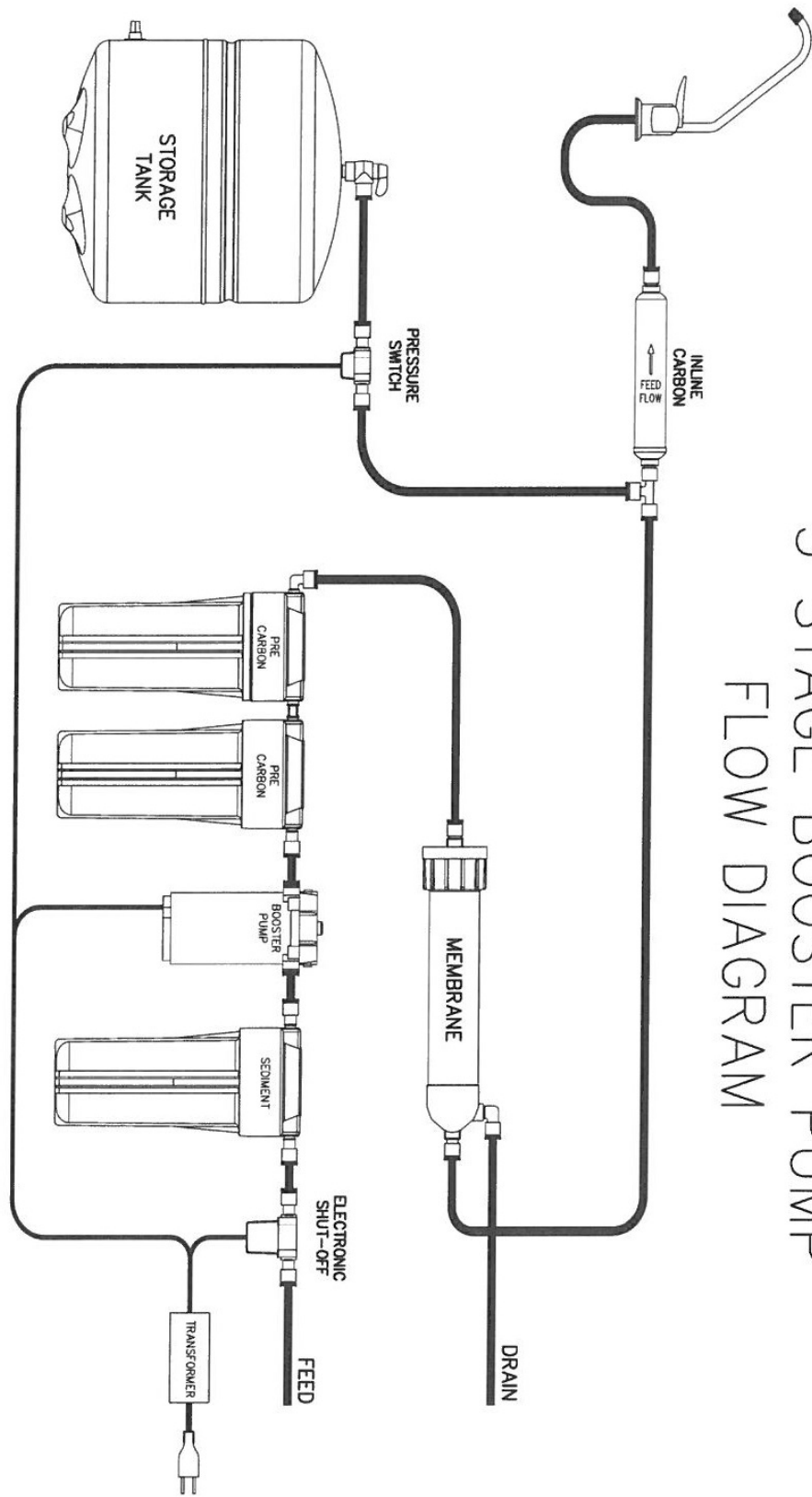

SYSTEM WARRANTY

One-Year Limited Warranty

Warranty Terms

Subject to the terms and conditions set forth hereinafter, manufacturer (hereafter “Manufacturer”) warrants to the original purchaser (hereafter the “Customer”) that the systems and products manufactured by the Manufacturer are free from defects in material and in workmanship for twelve (12) months from the Warranty Commencement Date (as defined below) only when used strictly in accordance with the applicable operating instructions and within the range of the operating conditions specified by the Manufacturer for each such product.

In order to maintain the Manufacturer’s Warranty, an operating log must be maintained and copies will need to be sent to your local dealer or distributor for review. This Warranty does not extend to systems, equipment, or components manufactured by others, nor to systems, equipment, or components manufactured by others and distributed by the Manufacturer. This Warranty does not extend to equipment or components manufactured by others which have been incorporated into a product by the Manufacturer but, if allowable, the Manufacturer hereby assigns, without Warranty, to the Customer its interest, if any, under any Warranty made by the Manufacturer of such equipment or component. This Warranty does not cover disposable items such as fuses, o-rings, regeneration materials/chemicals, or other such disposable items, which must be replaced periodically under the normal and foreseeable operating conditions of the goods warranted hereby.

Warranty Commencement Date

The Warranty Commencement Date for each product by the Manufacturer shall be the later of the date of: (1) receipt by the Customer, or (2) the date of installation at the Customer’s premises provided that such installation must occur within three (3) months of shipment from the Manufacturer’s manufacturing facility. In no event shall the Warranty Commencement Date exceed three (3) months from the shipment from Manufacturer’s facility. The Customer shall provide proof of purchase in order to exercise rights granted under this Warranty. If requested by the Manufacturer, the Customer must also provide proof of the installation date. Proof of installation shall be returned by Customer to the Manufacturer within thirty (30) days after installation by virtue of supplying a Warranty Validation Card supplied with each Manufacturer product fully completed and signed in ink by the Customer and the authorized installer of the product.

Warranty Service

MANUFACTURER’S OBLIGATION UNDER THIS WARRANTY IS LIMITED TO THE REPAIR OR REPLACEMENT (AT MANUFACTURER’S SOLE DISCRETION) OF ANY PRODUCT, OR COMPONENT THEREOF, PROVED TO BE DEFECTIVE IN MATERIAL OR WORKMANSHIP WITHIN THE COVERED WARRANTY PERIOD.

The Customer, at the Customer’s risk and expense, shall be responsible for returning such product or component, only after obtaining a Return Goods Authorization (RGA) number from the Manufacturer, arranging for freight prepaid, and in conformance with any special packaging and shipping instructions set forth on the operation documentation or RGA instructions, or as otherwise reasonably required, to Manufacturer’s address, together with (1) RGA number issued by the Manufacturer at Customer’s request; (2) proof of purchase and, if necessary, proof of installation date; (3) a Return Goods Authorization Form; (4) a description of the suspected defects; (5) the serial number of the Manufacturer product alleged to be defective; and (6) a description of the type of water and pretreatment equipment which has been utilized in connection with the product, if any; (7) an operating log, which can be found in the product manual. Manufacturer shall, in Manufacturer’s reasonable discretion, be the sole judge of whether a returned product or component is defective in material or workmanship.

Required or replaced products or components shall be returned surface freight. In genuine emergency situations, Manufacturer will at Manufacturer’s sole discretion forward replacement parts to Customer without waiting for

authorized return of the questionable part(s). In such cases, Customer will issue a purchase order or other payment guarantee prior to shipment. If the returned part is found to have been misused or abused, or the defective part is not received by Manufacturer within thirty (30) days; the Customer will be invoiced for the replacement part(s) provided. This Warranty does not cover or include labor and/or travel to the Customer's premise or location or any other location. Charges of \$1000 per day plus associated travel expenses will be incurred by the Customer in providing the Warranty Service at any location other than Manufacturer's main headquarters; that is if the Manufacturer deems that the product is not covered by said Warranty. The Manufacturer reserves the right to precondition such travel to Customer's premises upon prepayment of Manufacturer's anticipated costs of attending such premises.

Voidability of Warranty

This Warranty shall be void and unenforceable as to any Manufacturer product which has been damaged by accident, mishandling, abuse or has been repaired, modified, altered, disassembled or otherwise tampered with by anyone other than Manufacturer or an authorized Manufacturer service representative; or, if any replacement parts are not authorized by Manufacturer have been used, or, the product has not been installed, operated and maintained in strict accordance and adherence with the operating documentation and manuals for such product. Any expressed Warranty, or similar representation of performance set forth in the operation documentation for media or resin incorporated into a product by the Manufacturer shall be void and unenforceable unless the feed water requirements set forth in the operating documentation for such product are unequivocally and strictly adhered to.

Limitations and Exclusions

THIS WARRANTY AND REMEDIES DESCRIBED HEREIN AND HEREINABOVE ARE EXCLUSIVE AND IN LIEU OF ANY AND ALL OTHER WARRANTY OR REMEDIES, EXPRESSED OR IMPLIED, INCLUDING WITHOUT LIMITATION, ANY IMPLIED WARRANTY OF MERCHANTABILITY OR FITNESS FOR A PARTICULAR PURPOSE. IN NO EVENT SHALL THE MANUFACTURER BE LIABLE FOR ANY CONSEQUENTIAL, INCIDENTAL OR OTHER SIMILAR TYPES OF DAMAGES, FOR DAMAGES FOR THE LOSS OF PRODUCTION OR PROFITS, OR INJURY TO PERSON OR PROPERTY. NO PERSON HAS ANY AUTHORITY TO BIND THE MANUFACTURER TO OTHER THAN WHAT IS SET FORTH ABOVE.

THIS WARRANTY GIVES THE CUSTOMER SPECIFIC LEGAL RIGHTS AND THE CUSTOMER MAY ALSO HAVE OTHER RIGHTS WHICH VARY FROM JURISDICTION TO JURISDICTION. THE PARTIES RECOGNIZE AND AGREE, THAT IN ALL RESPECTS THE LAWS OF THE STATE OF CALIFORNIA SHALL APPLY TO AND SHALL GOVERN ANY INTERPRETATION OR LEGAL SIGNIFICANCE OF THIS DOCUMENT.

NO WARRANTY OR OTHER LIABILITY OF THE MANUFACTURER TO CUSTOMER UNDER THIS AGREEMENT OR OTHERWISE WILL IN ANY EVENT EXCEED THE COST OF REPLACEMENT OF THE APPLICABLE MANUFACTURER PRODUCT, PART, OR ACCESSORY THAT IS SUBJECT TO ANY BREACH OF MANUFACTURER'S WARRANTY. MANUFACTURER WILL NOT BE LIABLE FOR ANY DAMAGE TO ANY PROPERTY OF CUSTOMER OR TO CUSTOMER'S CUSTOMERS FOR ANY CONSEQUENTIAL, INCIDENTAL, OR ECONOMIC LOSS OR COMMERCIAL DAMAGE WHATSOEVER. REMEDIES HEREIN PROVIDED ARE EXPRESSLY MADE THE SOLE AND EXCLUSIVE REMEDIES FOR BREACH OF ANY WARRANTY OR OTHER OBLIGATION HEREUNDER EXPRESS OR IMPLIED OR FROM THE OPERATION OF LAW.